

NO.	REV.	DATE	BY
1	CREATED		

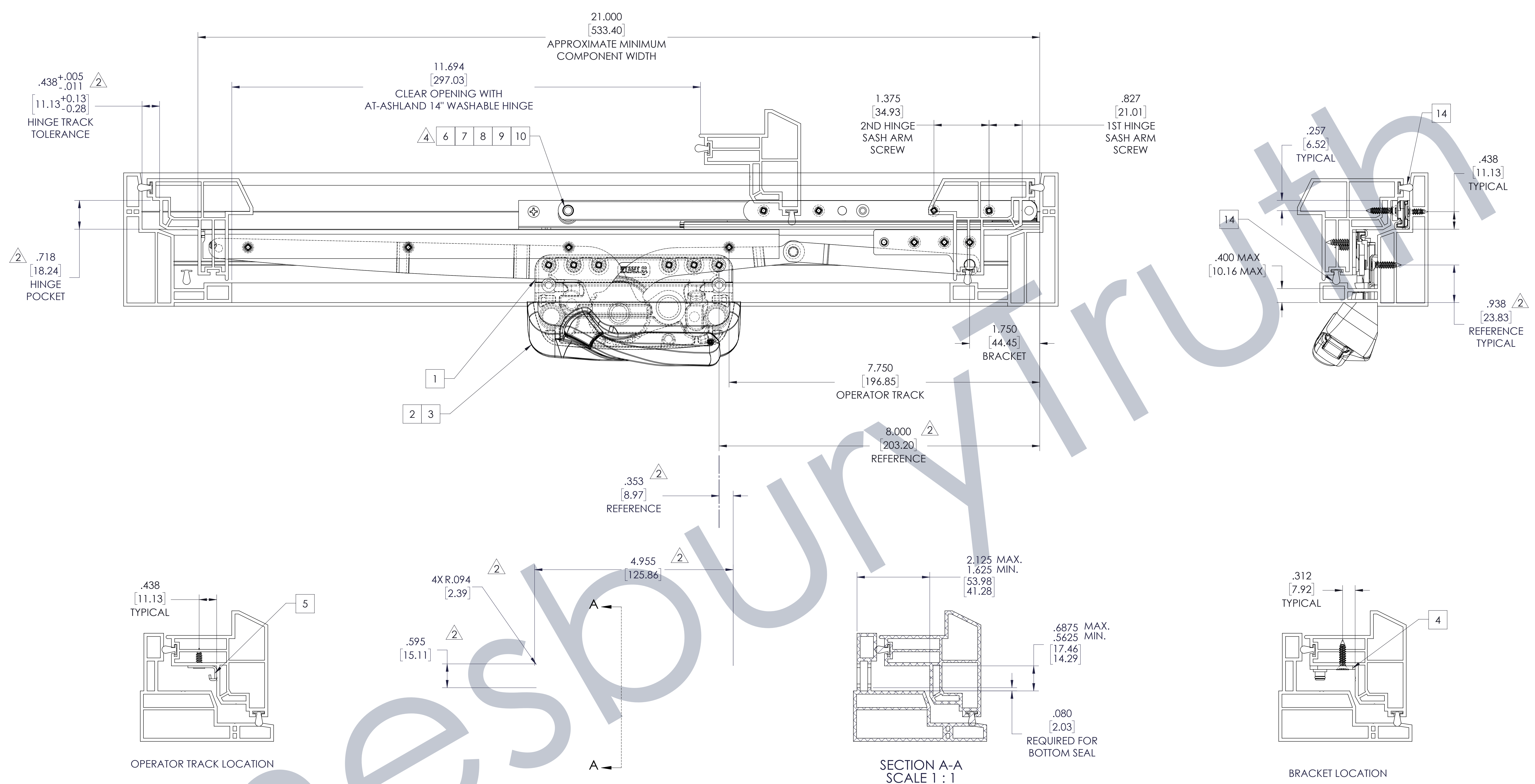

OPERATOR TRACK LOCATION

ITEM NO.	PART NUMBER	DESCRIPTION	QTY.
1	50.11.XX.XXX	OPER. ENCORE LH S DUAL ARM LP	1
2	32458	GASKET	1
3	12614.XX	HANDLE AND COVER ASSEMBLY	1
4	11661.XX	BRACKET, RH S STUD	1
5	32384.XX	TRACK, OPR CSM NH 14.5 PT STL	1
6	14.97.00.XXX	HGE CSM UL TRK NF WSH	1
7	14.97.00.XXX	HGE CSM LL TRK NF WSH	1
8	14.97.00.XXX	HGE CSM UL ARM - WSH EG SP	1
9	14.97.00.XXX	HGE CSM LL ARM - WSH EG SP	1
10	24309	HINGE STOP	2
11	14103	SCREW, 8 X 3/4 PH FH SMS SS 18-8	10
12	19070	SCREW 7X1/2 PH FU SMS SS18-8	14
13	19105	SCREW 7X3/4 PH FH SMS SS18-8	8
14	Q375T270	Q-LON BULB SEAL	

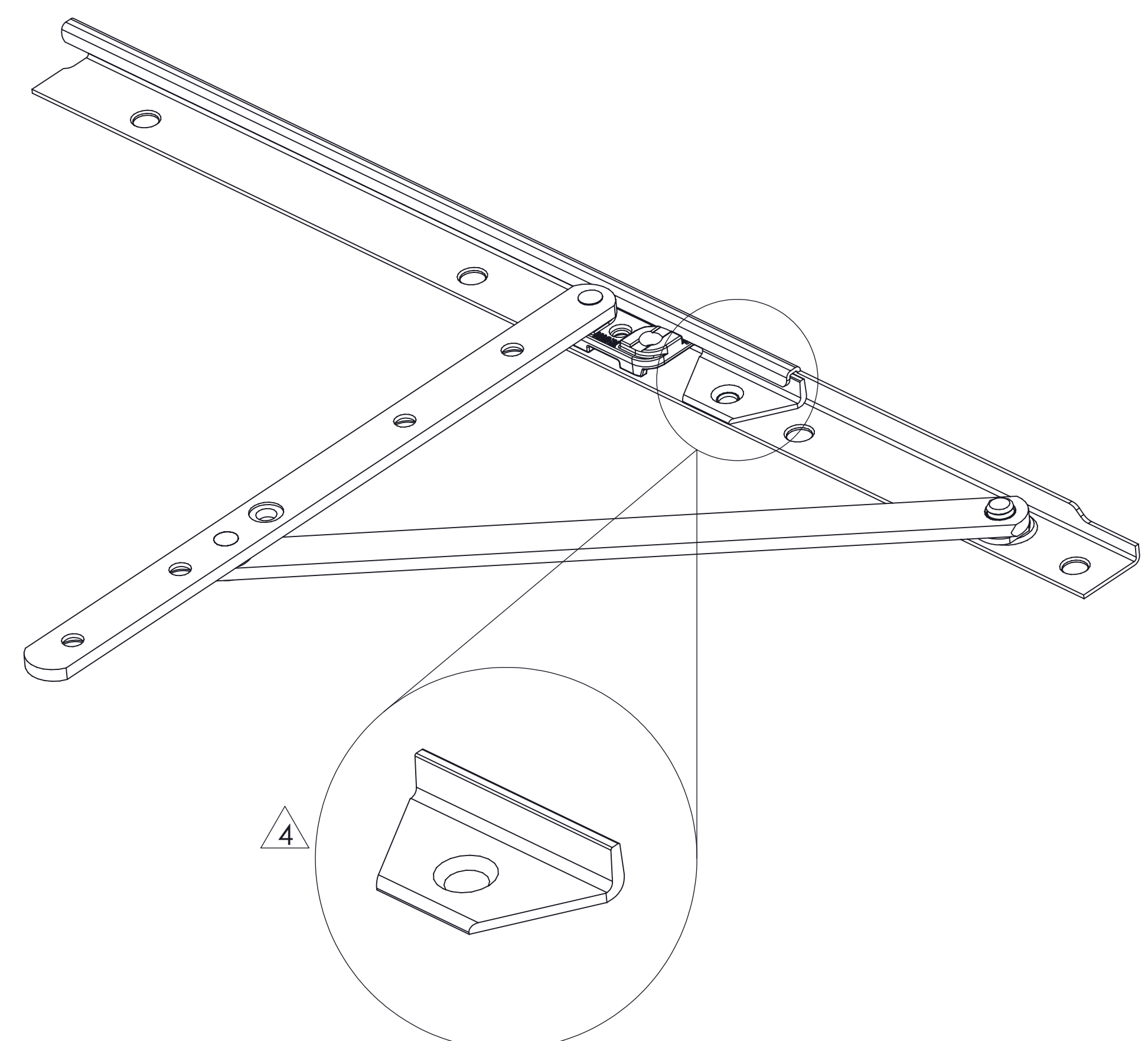

NOTES:

- HARDWARE MAY ACHIEVE A MAXIMUM WINDOW SIZE OF 40" W X 84" H (COMMERCIAL). PER AAMA HARDWARE LOAD TEST. -96 LB SASH RESULTS IN 5 LB. FORCE FOR ADA HANDLE OPERATION (RESIDENTIAL). -108 LB SASH PERMITTED FOR AAMA HARDWARE LOAD TEST (COMMERCIAL). -FOR COMMERCIAL RATING THE MAXIMUM FRAME AREA (WIDTH X HEIGHT) MUST BE REDUCED BY 20%. CHECK WITH EXTRUDER FOR PROFILE PERFORMANCE DATA.
- HOLD THESE DIMENSIONS AS CLOSE TO THEIR MINIMUM AS MANUFACTURING TOLERANCES ALLOW.
- SNUBBERS RECOMMENDED ON WINDOWS OVER 30 INCHES HIGH, CENTERED ON SASH AND FRAME ON HINGE SIDE OF THE WINDOW. SEE SNUBBER APPLICATION DRAWING.
- WARNING! IT IS RECOMMENDED TO INSTALL HINGE STOPS 24309 IN EACH HINGE TRACK FOR SAFETY.
- WARNING! SHIPPING BLOCKS 24784 IS RECOMMENDED IN EACH WINDOW ASSEMBLY. REFERENCE TECH NOTE #13 FOR CORRECT INSTALLATION OF SHIPPING BLOCKS.
- WARNING! ONLY TRAINED PROFESSIONALS SHOULD DISCONNECT HARDWARE TO SERVICE WINDOWS. FAILURE TO DO SO COULD CAUSE SERIOUS WINDOW DAMAGE AND/OR PERSONAL INJURY.
- REFERENCE TECH NOTE #7 AND 9 FOR MOUNTING SCREW COMPATIBILITY AND CORROSION INFORMATION.
- REFERENCE TECH NOTE #8 FOR PROPER CARE OF HARDWARE.
- SEE TECH NOTE #14 FOR PROPER INSTALLATION OF AN OPERATOR COVER AND NESTED FOLDING HANDLE.
- REFERENCE TECH NOTE #3 FOR SASH SAG TIPS.
- SEE WEBSITE FOR COVER AND HANDLE OPTIONS.

TRUTH HARDWARE MAKES NO WARRANTY OR REPRESENTATION OF ANY KIND, EXPRESS OR IMPLIED, WITH RESPECT TO QUALITY, CONTENT, FORM, PERFORMANCE, FITNESS FOR PURPOSE, MERCHANTABILITY OR OTHERWISE OF THE APPLICATION DRAWINGS PROVIDED. THESE DRAWINGS ARE USED AT THE RECIPIENT'S OWN RISK AND TRUTH HARDWARE HAS AND SHALL HAVE NO RESPONSIBILITY FOR RECIPIENTS OR ANY THIRD PARTY'S USE OF THESE DRAWINGS OR ANY OF THE INFORMATION CONTAINED THEREIN. THE RECIPIENT AGREES TO INDEMNIFY, DEFEND, AND HOLD HARMLESS TRUTH HARDWARE AND ITS EMPLOYEES AND THEIR SUCCESSORS AND ASSIGNS FROM AND AGAINST ANY AND ALL CLAIMS, SUITS, LOSSES, DAMAGES OR COSTS INCURRED FROM USING THESE DRAWINGS OR ANY CONTENT THEREOF.

COMMENTS

Amesbury Truth
 Engineered Solutions. Trusted Brands.
 700 West Bridge Street
 Owatonna, MN 55060
 Telephone 507-451-5620

THIS DRAWING IS THE PROPERTY OF TRUTH HARDWARE. THE INFORMATION THEREON IS TO BE TREATED AS CONFIDENTIAL. IF IT IS NOT TO BE USED, COPIES OR DISCLOSED TO OTHER PARTIES WITHOUT OUR WRITTEN CONSENT.

DRAWN BY: M. NEFF DATE: 9/17/2021
 CHECKED BY: MDN SCALE: 1:8

PROJECT: GENERIC ENCORE LP DUAL ARM APPLICATION
 DRAWING NO.: 21257C
 REVISION: A
 TITLE: E

DO NOT SCALE DRAWINGS